



## TYPE: TELSHACK-B



# TELSHACK-B Wireless Crosby™ Bow Load Shackle

## Description

The TELSHACK-B range of telemetry load shackles are manufactured using the Crosby™ G2130 (12 to 25 tonne) and G2140 (40 to 120 tonne) shackles. Suitable for use in a wide range of industrial and marine weighing applications, these load shackles are robust, reliable and easy to install.

The unique telemetry housing is manufactured from tough high performance polyamide resin making it strong yet light, resulting in a better balanced load shackle when compared to others available on the market. Two clips enable you to open the housing to access and change the two AAA alkaline batteries, while the internal electronics underneath remain completely sealed. This includes the antenna to ensure maximum protection from damage. The built in radio telemetry electronics operates on the 2.4GHz license free frequency.

The TELSHACK-B is supplied as standard without any additional wireless devices to enable greater flexibility with the configuration and ordering of the product. The TELSHACK-B can be used with any of the T24 range of wireless instrumentation, whether this be for a simple display system using the T24-HS-LS, or more complex systems using multiple load cells and multiple wireless devices.

For more sophisticated systems, including datalogging or monitoring/reporting requirements, we are able to offer a robust tablet PC with installed software for use with single or multiple load cell installations. Our sales team will be happy to discuss the best wireless system configuration to suit your requirements.

The TELSHACK-B series can be provided as shown in this datasheet or can be modified to meet a particular application requirement. We are always pleased to discuss any special requirements that can be accommodated.

## Features

- Ranges from 12 to 120 tonnes
- Forged high tensile carbon steel construction
- Environmentally sealed to IP67
- Simple installation and operation
- Shackle and load pin fully certified
- Optional load centralising bobbin
- Many other options available

## Typical Applications

- Under-hook hoist/crane weighing
- Cable tension monitoring
- Towing/mooring Tension
- Crane safe load monitoring
- Beam proof loading

## Specification

Rated load (tonnes)	12, 17, 25, 40, 55, 85, 120,
Proof load	150% of rated load
Ultimate breaking load	300% of rated load
Non-linearity	<±1% of rated load (typically)
Non-repeatability	<±0.1% of rated load
Transmission distance	Up to 600 metres (clear line of sight)
Battery life	>300 hours typically (continuous use with 1.2Ah batteries)
Battery (standard)	2 x AAA Alkaline (supplied with 1.2Ah batteries)
(ATEX)	AAA L92 Lithium x 2 (supplied with 1.2Ah batteries)
Operating temperature range	-20 to +55°C (-20 to +50°C for Ex i)
ATEX certification details	II 2G Ex ib IIC T4 Gb
Environmental protection level	IP67
Telemetry housing	Polyamide resin

## Available Options

- Special ranges and capacities up to 2000t
- Hazardous Area certified - Intrinsically Safe (Ex i)
- Centralising load bobbin
- Special telemetry systems available
- Lloyds, ABS, DNV or other third party witnessing
- Various wireless accessories available. See T24 range of wireless products

Ex i



SCIGATE AUTOMATION (S) PTE LTD

No 1 Build Road, Block 22, #01-01 Singapore 080892  
Tel: (65) 6561 0488 Fax: (65) 6561 0888  
Email: sales@scigate.com.sg Web: <http://scigate.com.sg/>

Business Hours: Monday - Friday 8:30AM - 5:15PM



# TELSHACK-B Wireless Crosby™ Bow Load Shackle

## Special Options

Special ranges	The TELSACK-B can be supplied in any range, between 12te and 120te and calibrated as required. Usually we will choose the nearest standard shackle size. We can also offer special design shackles up to 2000te. Please contact our sales team for more details.
Centralising bobbin	We can offer an optional centralising bobbin. This helps improve the overall load cell accuracy in certain cable tension applications. The bobbin is shown pictorially in the drawing below.
Multi-shackle systems	It is possible with the T24-HA handheld telemetry display to use up to 12 shackles with a single handheld. Each shackle is paired with the handheld and can be used to view individual load cells or summated load cells. These values can be sent to a printer or a PC.
Hazardous Area	We can supply ATEX/IECEx certified load shackles for use in Zone 1 and Zone two hazardous areas.

## Dimensions

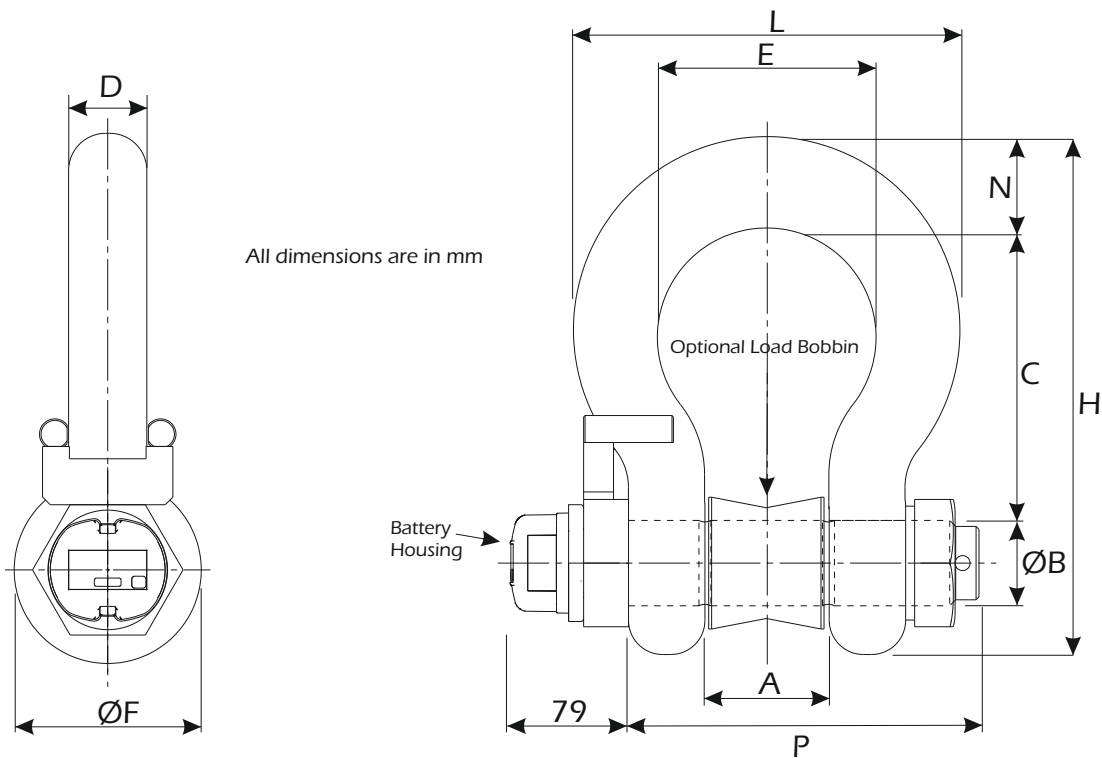

Rating (tonnes)	A	ØB	C	D	E	ØF	H	L	N	P	Weight (kgs)	Resolution (tonnes)
12	51.5	35.1	119	31.8	82.5	76	210	146	35.1	171	8	0.01
17	60.5	41.4	146	38.1	98.5	92	254	175	41.1	201	12	0.02
25	73	51	178	44.5	127	106	313	225	57	236	18	0.02
40	73.2	50.8	178	46.7	127	106	313	224	57.2	236	18	0.05
55	82.6	57.2	197	52.8	146	122	347	258	61	269	25	0.05
85	105	69.9	267	68.8	184	148	455	324	79.2	351	45	0.1
120	127	82.6	330	79.2	200	165	546	371	92.2	387	85	0.1

Note 1: Part numbers for ATEX versions will be suffixed with -ATEX-I e.g. TELSACK-B-17T-T24-ATEX-I.

Note 2: Dimensions may change for hazardous area versions.

A summary of available wireless devices that can be used to enhance the AWLL in your application can be viewed on the next page of this datasheet.

For further assistance on system configuration, please call us or email your requirements to [sales@lcm systems.com](mailto:sales@lcm systems.com).

# TELSHACK-B Wireless Crosby™ Bow Load Shackles



## Wireless Receivers/Display Options



**T24-HS-LS**  
Simple wireless display for connecting to 1 load cell



**T24-HA**  
Wireless display for connection to up to 12 load cells



**T24-HR**  
Wireless display for connecting to multiple load cells



**X24-HD**  
ATEX Wireless display for connection to up to 24 load cells

## Wireless Base Station Options



**T24-BSu**  
Wireless USB connected base station



**T24-Bsd**  
Wireless compact USB connected base station



**T24-BSue**  
Wireless USB extended range base station



**T24-BSi**  
Wireless USB, RS485, RS232 connected base station

## Wireless Output Module Options



**T24-RM1**  
Wireless relay switch output module



**T24-SO**  
Wireless serial ASCII output module



**T24-AO1**  
Wireless analogue output module



**T24-PR1**  
Wireless surface mounting tally roll printer



**T24-AR**  
Wireless range extender repeater module

## Wireless Software Options



LCM Systems are able to offer various software solutions for our wireless range of load cells. We encourage you to speak to our sales team to discuss any standalone software requirements you may have.

The solutions we regularly offer include centre of gravity weighing and reporting, multiple load cell display & reporting and PC based datalogging. Other solutions can also be offered.

For more detailed information regarding wireless instrumentation visit [www.lcmsystems.com/T24](http://www.lcmsystems.com/T24)

www.lcmsystems.com

LCM Systems Ltd

Unit 15, Newport Business Park, Barry Way  
Newport, Isle of Wight PO30 5GY UK

Tel: +44 (0)1983 249264

sales@lcm systems.com

www.lcm systems.com

LCM Systems (România)

Strada Ștefan Cel Mare 26a,  
Tunari, cod.077180, Ilfov, România

Tel: +40 (0)77 4641899

ro@lcm systems.com

www.lcm systems.ro

Due to continual product development, LCM Systems Ltd reserves the right to alter product specifications without prior notice.

Issue No. 8

Issue date: 08/11/2021

APPROVED

(unapproved if printed)